



AKSA Power Generation has been producing industrial generator sets with an innovative compact design and excellence in quality for over 30 years. AKSA has been providing reliable power through three main production plants and over 15 branch offices worldwide.

General Characteristics

Model Name	ANG360-5
Engine Make	PSI (Doosan)
Engine Model	18.3L
Alternator Make	Stamford
Control Panel Make & Model	DSE 7320
Frequency & Speed	50Hz, 1500rpm
Enclosure Make & Model	AKSA AUL 71A/72A



Genset Rating

Fuel Type	Engine	Alternator	Voltage	Standby Power	Standby Current	Prime Power	Prime Current
Natural Gas	18.3L	HCI434E	400/230V	360kVA	519A	325kVA	469A
LP Gas	18.3L	HCI434D	400/230V	270kVA	389A	N.A.	N.A.

Stand-by Power (Maximum): Power available at variable load in the event of main power network failure. No over load is permitted.
 Prime Power: Power available at variable load in lieu of a main power network. Overload of 10% is permitted for 1 hour in every 12 hours of operation.
 The above ratings represent the engine performance capabilities to conditions specified in accordance with ISO 8528/5 & ISO3046.
Derating may be required for conditions outside of the test conditions.

Codes & Standards

The Generator set is designed and manufactured in a facility certified to **ISO9001** standards.

The Generator set is designed and manufactured in a facility certified to **ISO14001:2015** standards.

AKSA Power Generation provides **single source responsibility** for the generator set & accessories.

The generator set, with its components, are **prototype tested** and **production tested**.

The generator set meets **NFPA70, 99, 110, 37** Level 1 when equipped with the necessary accessories and installed per NFPA standards.



*Manufacturer reserves the right to make changes in model, technical specifications, color, equipment and accessories without prior notice.



Engine Data

Manufacturer	PSI
Model	NGE 18.3L
Displacement & Cylinders	18.3 L / 10 Cylinders
Engine Type	V-type, 4 Cycle
Engine Speed	1800rpm
Engine Standby Power NG	320kW
Engine Standby Power LP	247kW
Aspiration	Turbo Charge Air Cooled
Compression Ratio	10.5 : 1
Bore / Stroke	128 mm / 142 mm
Governor type	Electronic

Fuel System

Fuel Type	NG, LP Gas/Dual Fuel
NG Supply pipe size	2 x 2" or 3" NPTF
Maximum EPR Rated Pressure	6.9 kPa / 1.0 psi
Recommended Max Pressure	2.7 kPa / 11.0 inH2O
Recommended Min Pressure	1.7 kPa / 7.0 inH2O
Max LPG vapor Pressure to EPR	2.7 kPa / 11.0 inH2O

Fuel Consumption

	Natural Gas	LP Gas
Standby Power (100%)	2892 cfh 81.9 m ³ /hr	1100 cfh 31.1 m ³ /hr
Standby Power (75%)	2255 cfh 63.8 m ³ /hr	860 cfh 24.3 m ³ /hr
Standby Power (50%)	1735 cfh 49.1 m ³ /hr	660 cfh 18.7 m ³ /hr

Electric System

System Voltage (dc)	24V
Battery Qty, Rating	2 x 120Ah

Cooling System

Radiator Cooling System Type	Closed Circuit
Coolant Capacity	46.7 gal / 212 L
Cranking Temperature	160 °F / 71 °C
Full Open Temperature	185 °F / 85 °C

Exhaust System

Type	Water cooled manifold
Max. allowable back pressure	10.2 kPa
Max Turbine Inlet Temperature	1382 °F / 750 °C
Exhaust Gas Flow at Rated Power @ 1350 °F	2016 cfm / 57.1m ³ /min

Air Intake System

Combustion Air Required	634 cfm / 18 m ³ /min
Max Intake Air Restriction (Clean Element)	1.24 kPa / 5 inH2O
Air Filter Type	Dry Paper Element

Lubrication System

Oil Specifications	SAE 15W-40 Low Ash Gas Engine oil, API CD/CF or higher
Oil Capacity, Min-Max	29.5 - 37 Qts 28 - 35 L
Oil filter; qt, type	2, Cartridge
Min - Max Oil Pressure at Rated Speed	43.5 psi - 94.5 psi 3 bar - 6.5 bar



Alternator Data

Manufacturer	Stamford
Standards	BS EN 60034
Control System	PMG
A.V.R.	MX341
Voltage Regulation	± 1 %
Insulation System	Class H
Protection	IP23
Rated Power Factor	0.8
Stator Winding	Double Layer Concentric
Winding Pitch	Two Thirds
Winding Leads	12
Telephone Interference	THF < 2 %
Waveform Distortion	No Load < 1.5 %
Maximum Over speed	2250 rev/min

Battery Charger & Electrical System Data

Manufacturer	ComAp
Model	InteliCharger
Input Voltage	85V ~ 264V AC
Output Voltage / Current	27.2V Float / 2.5A pk

Jacket Water Heater Data

Manufacturer	Hotstart
Model	CTM25110-N00
Input Voltage	120V
Power	2500W

Controller Data

Manufacturer	DSE
Model	7320 MK II

Controller Features & Benefits

- Microprocessor controlled, UL & NFPA110 Compatible
- License free PC Software (Non-proprietary Software)
- IP65 rating offers increased resistance to water ingress
- Modules can be integrated to building management systems
- Real time clock provides accurate event log
- Four line back-lit LCD text display
- Five key menu navigation, two wire start/stop at Auto mode
- Front panel editing with PIN protection
- Support up to three remote display modules
- Configurable timers and alarms
- Multiple date and timer scheduler
- Integral PLC editor
- 'Protections disabled' feature
- Load switching (load shedding and dummy load outputs)
- Fully configurable via DSE Configuration Suite PC Software
- SCADA monitoring via DSE Configuration Suite PC Software

Protection

- ✓ Gen. Voltage – under / over
- ✓ Gen. Freq. – under / over
- ✓ Engine Speed – under / over
- ✓ Engine Oil Pressure – low
- ✓ Engine Temp – low / high
- ✓ Battery Voltage – low / high
- ✓ Weak Battery
- ✓ Fail to Start / Stop
- ✓ Charge Alternator Fail
- ✓ Over Current & Load (kW/kVAr)
- ✓ Unbalanced Load
- ✓ Independent Earth Fault
- ✓ Reverse Power
- ✓ Loss of Speed Signal

Instruments

- ✓ Gen. Voltage (L-L/L-N)
- ✓ Gen. Frequency
- ✓ Engine speed
- ✓ Oil Pressure
- ✓ Water Temperature
- ✓ Battery Voltage
- ✓ Run Time
- ✓ Phase Sequence
- ✓ Power monitoring (kWh/kVAh/kVArh)
- ✓ Power (kWh/kVAh/kVArh)
- ✓ Power Factor
- ✓ Generator Current
- ✓ Generator Load (%)
- ✓ Earth Current



Enclosure Features

- ✓ Heavy Duty Steel Structure
- ✓ E-Stop on Enclosure
- ✓ Control Panel Eliminated from Engine Vibrations
- ✓ Standard Sound Attenuation Foam
- ✓ Plastic Covered Corrosion Resistant Locks & Hinges

Enclosure Features

- ✓ Internally Mounted Exhaust System with Rain Cap
- ✓ Coolant Fill Cap
- ✓ Enclosure DC Light
- ✓ Oil & Coolant Drain Ports
- ✓ Easy Access for Maintenance

Open Skid Gen-Set Dimensions

Length	114.2 in / 2900 mm
Width w/o lift hooks	75 in / 1900 mm
Height	79.5 in / 2020 mm
Dry Weight	9000 lb / 4080 kg

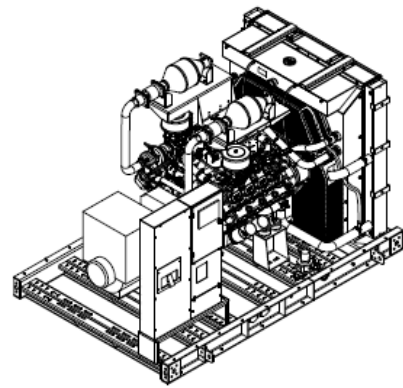

Enclosed Gen-Set Dimensions – Level 1

Length	206 in / 5220 mm
Width w/o lift hooks	77 in / 1965 mm
Height	101 in / 2565 mm
Dry Weight	14000 lb / 6350kg
Sound Pressure @ 7 meters	80 dBA

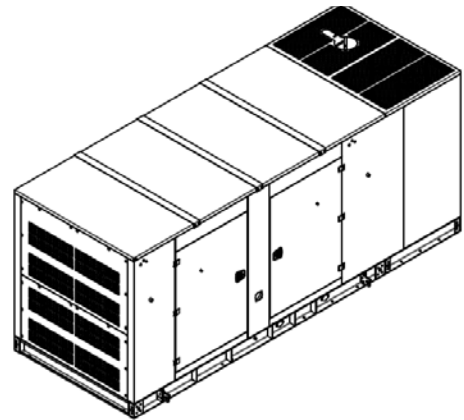

Enclosed Gen-Set Dimensions – Level 2

Length	224.6 in / 5705 mm
Width w/o lift hooks	77 in / 1965 mm
Height	101 in / 2565 mm
Dry Weight	14500 lb / 6575 kg
Sound Pressure @ 7 meters	77 dBA

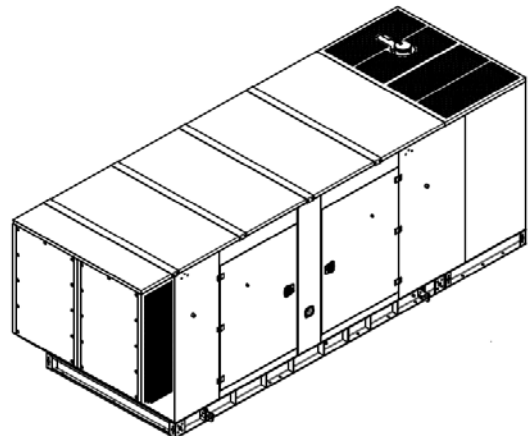

*Manufacturer reserves the right to make changes in model, technical specifications, color, equipment and accessories without prior notice.



Standard Features & Accessories

- ✓ Heavy Duty Steel Base Frame
- ✓ Engine Jacket Water Heater
- ✓ Battery and Battery Rack
- ✓ Battery Charger
- ✓ Battery Restraint
- ✓ Anti Vibration Pads between Engine/Alternator & Base Frame
- ✓ PMG Excitation
- ✓ Silencer Set w/Stainless Steel Flex
- ✓ Sound Absorb Foam for Enclosure
- ✓ Air Inlet & Outlet Rodent Guards
- ✓ Oil Drain Valve
- ✓ Coolant Drain Valve
- ✓ Flex Fuel Line Connected to Base Lock-off Valve
- ✓ Enclosure DC Light
- ✓ Jacket Water Heater Isolation Valves
- ✓ Protection Covers for Rotating Parts
- ✓ Exhaust Insulation Cover
- ✓ Low Fuel Supply Alarm
- ✓ Low Water Level Alarm
- ✓ Operations Manual
- ✓ 24 Months / 2000 hours Limited Standby Warranty

Optional Accessories

- Main Line CB (3 / 4 Poles – 80% / 100% rated)
- Upsize Alternator
- Anti-condensation Heater
- Voltage Regulation $\pm 0.5\%$ w/MX321 AVR
- Gas Regulator
- NG / LP Auto Changeover Control System
- LP Vaporizer for Liquid Fuel Supply Systems
- Oil Pan Heater
- Oil Temperature Display on Controller
- Manual Voltage Adjust Rheostat
- Enclosure AC Light
- Remote Annunciator Panel
- Remote Control & Monitoring Panel
- Advanced SMS Messaging
- Control Panel Heater
- Battery Disconnect Switch
- Battery Heater
- Battery Charger 10/20 Amp
- Shunt Trip / Aux Contacts
- Spring Anti-vibration Isolators
- Synchronization System Adders
- Automatic Transfer Panel (ATS)
- 5 Years / 2000 hours Limited Comprehensive Warranty

AKSA POWER GENERATION USA LLC

371 Exchange Street, West Monroe,
Louisiana, 71292

Tel: 318.855.8377 Fax: 318.855.8381

E-mail: sales@aksausa.com

AKSA Power Generation USA is a member of

**KAZANCI HOLDING****DISTRIBUTED BY:**